

W24L100-SPA269-P1

23.8" IP69K Stainless Display



KEY FEATURES

- 23.8" with Projected Capacitive Multi-Touch (PCAP)
- Fanless cooling system, IP69K Stainless Display
- SUS 316 / AISI 316 stainless steel for food and chemical industries
- Full IP69K waterproof enclosure
- A true flat, easy-to-clean front surface with edge-to-edge design
- Waterproof sealed conduit pipe for cable protection
- Supports VESA mount and Yoke mount stand
- Optical bonding (optional)



SPECIFICATIONS

Display	
Resolution	1920x1080
Contrast Ratio	3000:1
Display Color	16.7M Colors
Active Area	527.04x296.46 mm
Size	23.8 inches
Panel Brightness	250 nits
View Angles	89,89,89,89
Touch / Glass	Projected Capacitive Multi Touch Screen
Mechanical	
Dimension	620 x 390 x 56 mm
Enclosure	Stainless Housing
Mounting	VESA Mount Yoke Mount
Cooling System	Fanless design
Environment	
Operating Humidity	10% to 90% (non-condensing)
Storage Temperature	-20~60°C
Operating Temperature	0~45°C
IP rating	IP69K
Certification	
Certification	CE, FCC
IO Ports	
USB Port	1x USB type-A for touch screen control
Video	1x VGA 1x HDMI (Optional)
Indicator	1 x LED Indicator for power 1 x LED Indicator for status
Control	
Button	1 x Power Button 1 x Adjust up button 1 x Adjust down button 1 x ESC (Auto) button 1 x OK (Menu) button
Accessory	
Accessory	1 x Waterproof Conduit 1.5m 1 x Waterproof Conduit 0.3m 2 x Elbow for connect the conduit 1 x AC to DC power adapter with power cord 1 x External USB cable for touchscreen control 1 x External HDMI cable 1 x D-sub15(male) to RJ45 adapter
Optional Accessory	1 x Open wire cable for phoenix connector (Optional) Yoke mount stand kit (Optional)

1 x D-sub15(female) to RJ45 adapter
 1 x External RJ45 male to male cable
 Manual
 VESA screws

Power

Power Rating 12V DC input

DIMENSIONS UNIT:MM

Winmate W24L100-SPA269-P

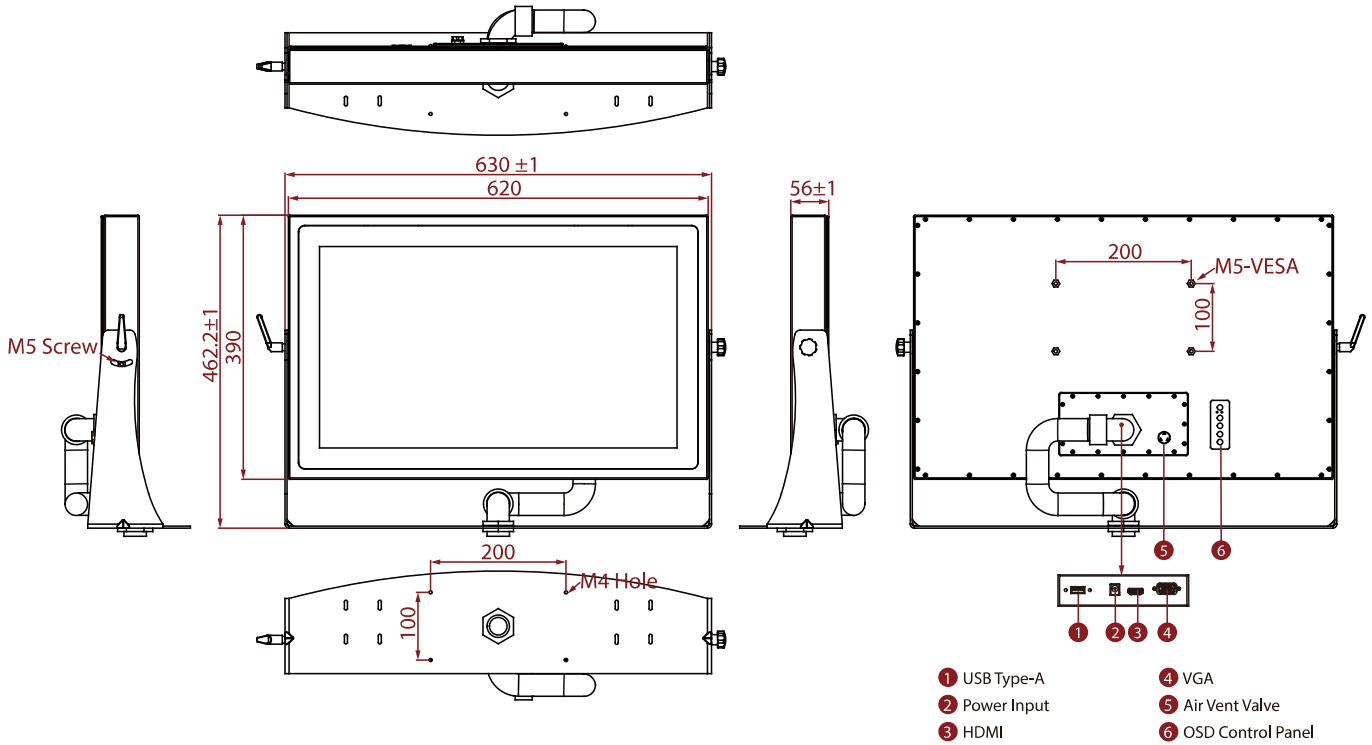

NOTE

1. This is a simplified drawing and some components are not marked in detail.
2. Please contact our sales representative if you need further product information.
3. All specifications are subject to change without prior notice.
4. The product shown in this datasheet is a standard model. For diagrams that contain customized or optional I/O, please contact the Winmate Sales Team for more information.

R15L100-SPC369-P1

15" IP69K Stainless Display with Waterproof sealed conduit pipe



KEY FEATURES

- 15" 1024x768 resolution with PCAP touch
- Fanless cooling system, IP69K Stainless Display with Waterproof sealed conduit pipe
- SUS 316 / AISI 316 stainless steel for food and chemical industries
- Full IP69K waterproof enclosure
- A true flat, easy-to-clean front surface with edge-to-edge design
- Waterproof sealed conduit pipe for cable protection
- Supports VESA mount and Yoke mount stand
- Optical bonding (optional)



SPECIFICATIONS

Display	
Resolution	1024x768
Contrast Ratio	2000:1
Display Color	16.2M Colors
Active Area	304.1x228.1 mm
Size	15 inches
Panel Brightness	300 nits
View Angles	88,88,88,88
Touch / Glass	Projected Capacitive Multi Touch Screen
Mechanical	
Dimension	378 x 301 x 56.2 mm
Enclosure	Stainless Housing
Mounting	VESA Mount Yoke Mount
Cooling System	Fanless design
Environment	
Operating Humidity	10% to 90% (non-condensing)
Storage Temperature	-20~60°C
Operating Temperature	0~45°C
IP rating	IP69K
Certification	
Certification	CE, FCC
IO Ports	
USB Port	1x USB type-A for touch screen control
Video	1x VGA 1x HDMI (Optional)
Indicator	1 x LED Indicator for power 1 x LED Indicator for status
Control	
Button	1 x Power Button 1 x Adjust up button 1 x Adjust down button 1 x ESC (Auto) button 1 x OK (Menu) button
Accessory	
Accessory	1 x Waterproof Conduit 1.5m 1 x Waterproof Conduit 0.3m 2 x Elbow for connect the conduit 1 x AC to DC power adapter with power cord 1 x External USB cable for touchscreen control
Optional Accessory	1 x Open wire cable for phoenix connector (Optional) Yoke mount stand kit (Optional)

- 1 x External HDMI cable
- 1 x D-sub15(male) to RJ45 adapter
- 1 x D-sub15(female) to RJ45 adapter
- 1 x External RJ45 male to male cable
- Manual
- VESA screws

Power

Power Rating 12V DC input

DIMENSIONS UNIT:MM

Winmate R15L100-SPC369-P

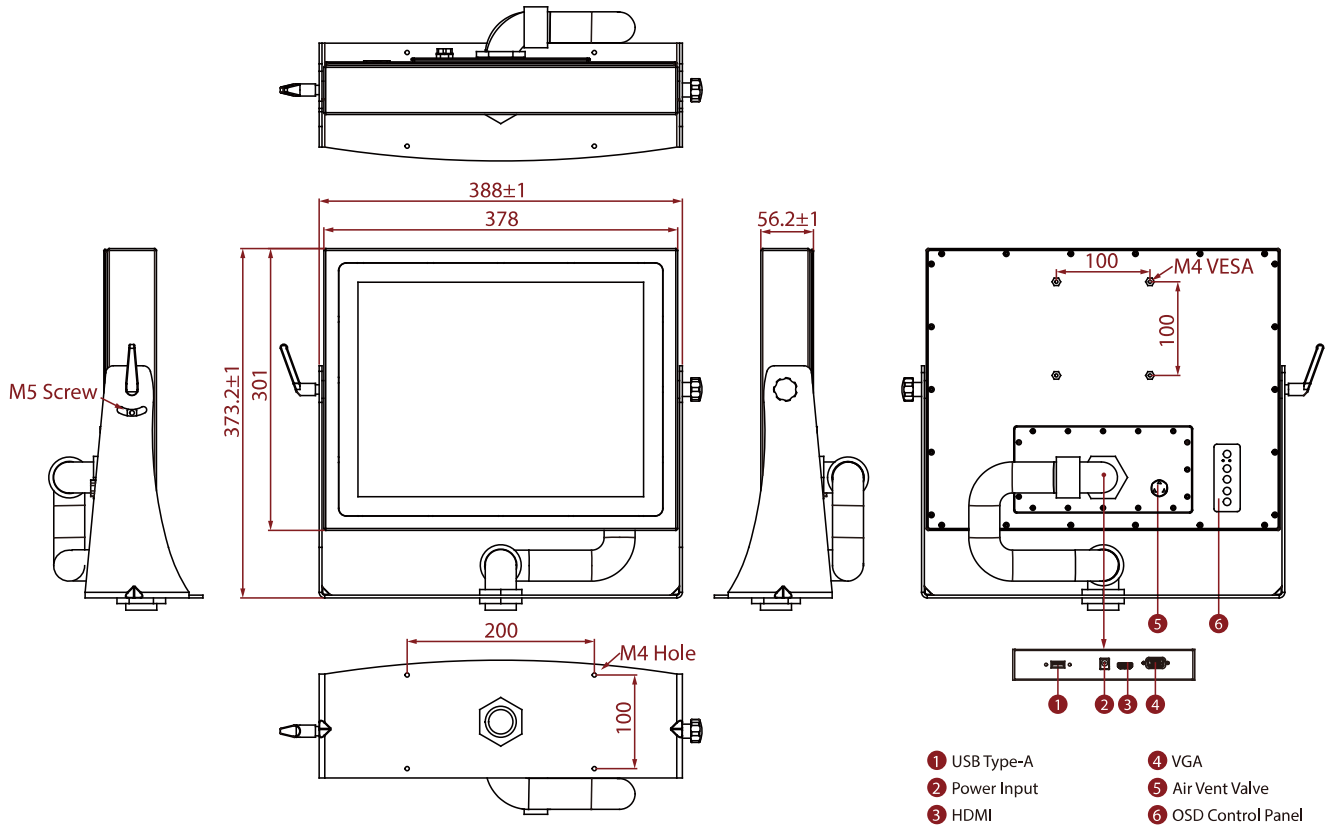

NOTE

1. This is a simplified drawing and some components are not marked in detail.
2. Please contact our sales representative if you need further product information.
3. All specifications are subject to change without prior notice.
4. The product shown in this datasheet is a standard model. For diagrams that contain customized or optional I/O, please contact the Winmate Sales Team for more information.

R19L100-SPM169-P1

19" IP69K Stainless P-Series Display



KEY FEATURES

- 19" Projected capacitive multi-touch screen
- Fanless cooling system
- SUS 316 / AISI 316 stainless steel for food and chemical industries
- Full IP69K waterproof enclosure
- A true flat, easy-to-clean front surface with edge-to-edge design
- Waterproof sealed conduit pipe for cable protection
- Supports VESA mount and Yoke mount stand
- Optical bonding (optional)



SPECIFICATIONS

Display			
Resolution	1280x1024	Size	19 inches
Contrast Ratio	1000:1	Panel Brightness	250 nits
Display Color	16.7M Colors	View Angles	85,85,80,80
Active Area	376.32x301.06 mm	Touch / Glass	Projected Capacitive Multi Touch Screen
Mechanical			
Dimension	468 x 395 x 57 mm	Mounting	VESA Mount Yoke Mount
Enclosure	Stainless Housing	Cooling System	Fanless design
Environment			
Operating Humidity	10% to 90% (non-condensing)	Operating Temperature	0~45°C
Storage Temperature	-20~60°C	IP rating	IP69K
Certification			
Certification	CE, FCC		
IO Ports			
USB Port	1x USB type-A for touch screen control	Video	1x VGA 1x HDMI (Optional)
Indicator	1 x LED Indicator for power 1 x LED Indicator for status		
Control			
Button	1 x Power Button 1 x Adjust up button 1 x Adjust down button 1 x ESC (Auto) button 1 x OK (Menu) button		
Accessory			
Accessory	1 x Waterproof Conduit 1.5m 1 x Waterproof Conduit 0.3m 2 x Elbow for connect the conduit 1 x AC to DC power adapter with power cord 1 x External USB cable for touchscreen control 1 x External HDMI cable 1 x D-sub15(male) to RJ45 adapter	Optional Accessory	1 x Open wire cable for phoenix connector (Optional) Yoke mount stand kit (Optional)

1 x D-sub15(female) to RJ45 adapter
 1 x External RJ45 male to male cable
 Manual
 VESA screws

Power

Power Rating 12V DC input

DIMENSIONS UNIT:MM

Winmate R19L100-SPM169-P

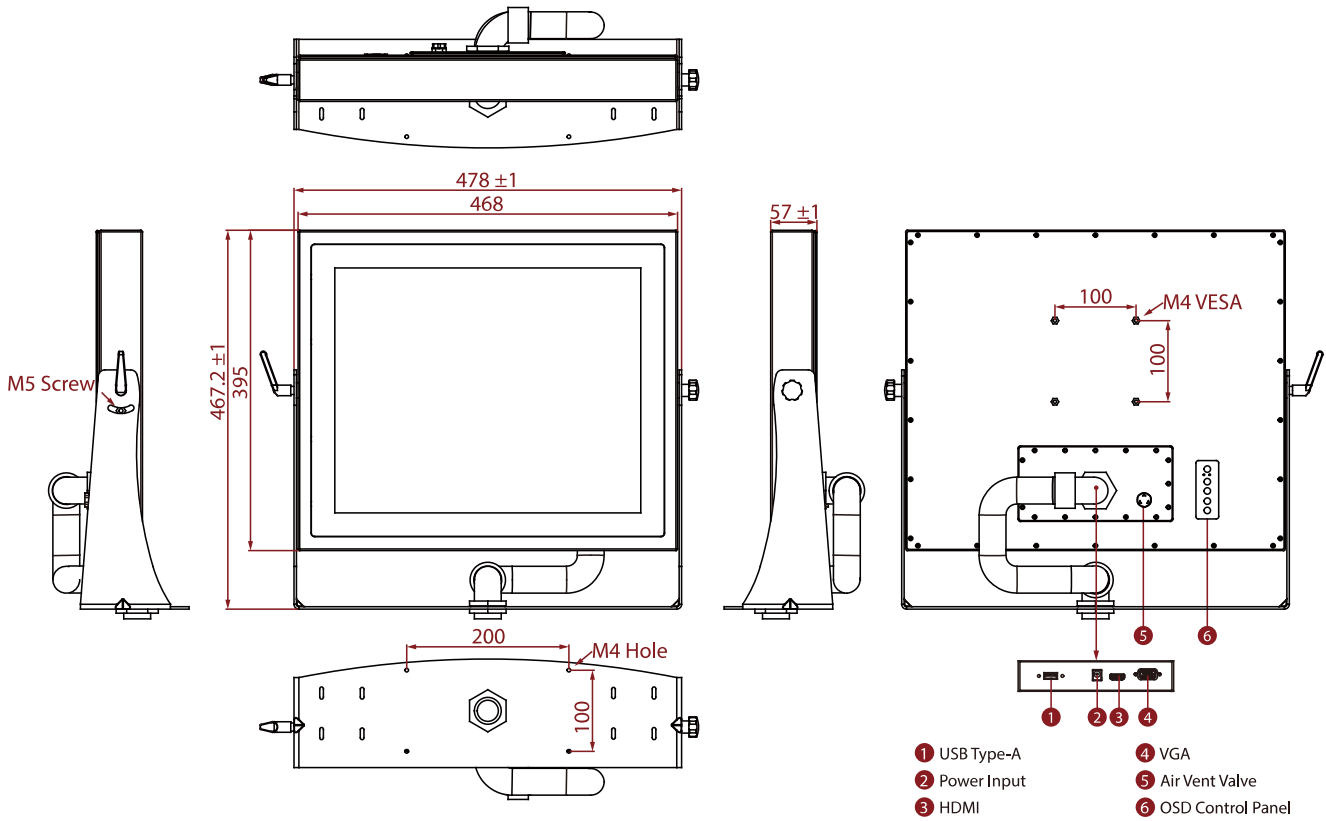

NOTE

1. This is a simplified drawing and some components are not marked in detail.
2. Please contact our sales representative if you need further product information.
3. All specifications are subject to change without prior notice.
4. The product shown in this datasheet is a standard model. For diagrams that contain customized or optional I/O, please contact the Winmate Sales Team for more information.

W22L100-SPA369-P1

21.5" IP69K Stainless P-Series Display



KEY FEATURES

- Projected capacitive multi-touch screen
- Waterproof Conduit pipe for extra protection
- SUS 316 / AISI 316 stainless steel for food and chemical industries
- Full IP69K waterproof enclosure
- A true flat, easy-to-clean front surface with edge-to-edge design
- Waterproof sealed conduit pipe for cable protection
- Supports VESA mount and Yoke mount stand
- Optical bonding (optional)



SPECIFICATIONS

Display			
Resolution	1920x1080	Size	21.5 inches
Contrast Ratio	3000:1	Panel Brightness	250 nits
Display Color	16.7M Colors	View Angles	89,89,89,89
Active Area	476.64x268.11 mm	Touch / Glass	Projected Capacitive Multi Touch Screen
Mechanical			
Dimension	541 x 337 x 56.2 mm	Mounting	VESA Mount Yoke Mount
Enclosure	Stainless Housing	Cooling System	Fanless design
Environment			
Operating Humidity	10% to 90% (non-condensing)	Operating Temperature	0~45°C
Storage Temperature	-20~60°C	IP rating	IP69K
Certification			
Certification	CE, FCC		
IO Ports			
USB Port	1x USB type-A for touch screen control	Video	1x VGA 1x HDMI (Optional)
Indicator	1 x LED Indicator for power 1 x LED Indicator for status		
Control			
Button	1 x Power Button 1 x Adjust up button 1 x Adjust down button 1 x ESC (Auto) button 1 x OK (Menu) button		
Accessory			
Accessory	1 x Waterproof Conduit 1.5m 1 x Waterproof Conduit 0.3m 2 x Elbow for connect the conduit 1 x AC to DC power adapter with power cord 1 x External USB cable for touchscreen control 1 x External HDMI cable 1 x D-sub15(male) to RJ45 adapter	Optional Accessory	1 x Open wire cable for phoenix connector (Optional) Yoke mount stand kit (Optional)

1 x D-sub15(female) to RJ45 adapter
 1 x External RJ45 male to male cable
 Manual
 VESA screws

Power

Power Rating 12V DC input

DIMENSIONS UNIT:MM

Winmate W22L100-SPA369-P

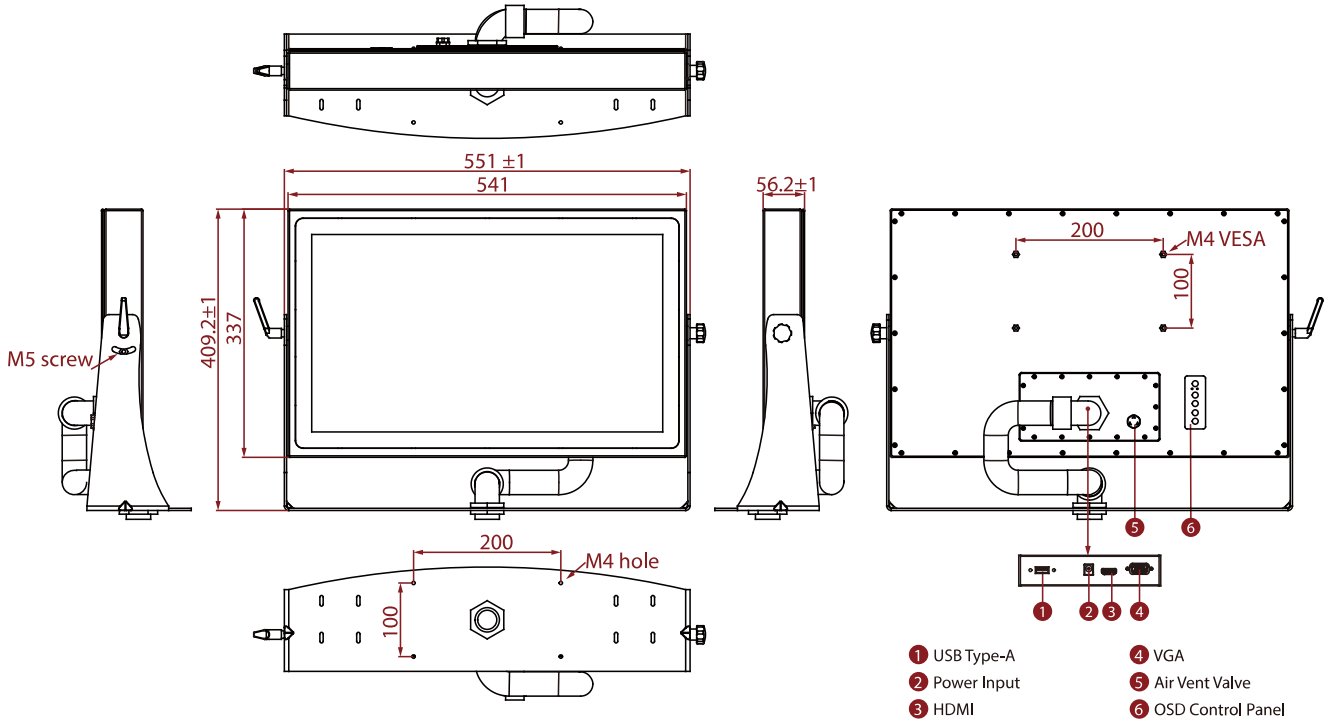

NOTE

1. This is a simplified drawing and some components are not marked in detail.
2. Please contact our sales representative if you need further product information.
3. All specifications are subject to change without prior notice.
4. The product shown in this datasheet is a standard model. For diagrams that contain customized or optional I/O, please contact the Winmate Sales Team for more information.