

PICO-IMX6



- The PICO-IMX6 is a System on Module (SOM) based on an NXP i.MX6 Solo, Duallite, or Quad multicore Cortex-A9™ processor clocking up to 1GHz.
- The PICO-IMX6 operates in commercial and industrial temperature ranges from -40 to 85°C. The system's built-in Vivante GC2000 GPU enriches the multimedia experience on interfaces such as HDMI, RGB TTL, LVDS, and an MIPI-CSI2 camera interface.
- The PICO-IMX6 is a member of the TechNexion “PICO pin-to-pin” product family, providing scalable solutions with industrial interfaces such as RGMII, USB, I²S, CAN, UART, SPI, I²C, PWM, GPIO for sensors for IIoT edge devices.
- Accelerate your time-to-market and reduce development costs with TechNexion pre-certified FCC / IC / CE / RCM / TELEC dual-band Wi-Fi 802.11 ac/a/b/g/n, Bluetooth.
- Linux, Yocto, Android runtime images and full source code available.

Specifications



yocto
PROJECT



Core System

Processor	NXP i.MX6 Solo NXP i.MX6 Duallite NXP i.MX6 Quad
Processor speed	up to 1GHz
Architecture	ARM Cortex-A9
Memory	up to 2GB DDR3
Storage	eMMC (16GB Default) MicroSD Cardslot (optional)
Board-to-Board Connector	Edison compatible connector PICO 70-pin Hirose connectors
System on Module	PICO System on Module

Connectivity

Network LAN	RGMII
Wi-Fi/Bluetooth	Qualcomm QCA9377 802.11 a/b/g/n/ac + BT (BR+EDR+BLE)
Antenna	MHF4 connector

Signaling

I/O	HDMI	SATA
	LVDS	SDIO
	RGB TTL	CAN
	MIPI CSI	UART
	MIPI DSI	SPI
	RGMII	I ² C
	PCIe	GPMC
	USB	PWM
	USB OTG	GPIO
	I ² S	

Video

Graphic Engine	Vivante GC320 (2D Composition) Vivante GC355 (Quad) Vivante GC880 (Solo/DualLite) Vivante GC2000 (Quad)
Video Decode	1080p30 + D1 (Solo/DualLite) 1080p60 H.264 (Quad)
Video Encode	1080p30 H.264 BP/Dual 720p
Camera	MIPI CSI (4 lanes)

Audio

Audio Codec	On carrier board
Audio Interface	I ² S (1 channel)

Operation Systems

Standard Support	Linux Yocto Android
Extended Support	Commercial Linux

Certification and Compliance

USA	FCC ID: 2AKZA-QCA9377
Canada	IC: 22364-QCA9377
Japan	TELEC: 201-180629
European Union	EN 55032 / EN 55024 EN 300 328 v2.1.1 EN 301 893 v2.1.1
Australia/New Zealand	RCM
Bluetooth Logo Certification	QDID150839 (Bluetooth 4.2) Compliant with RoHS / REACH directives

Block Diagram

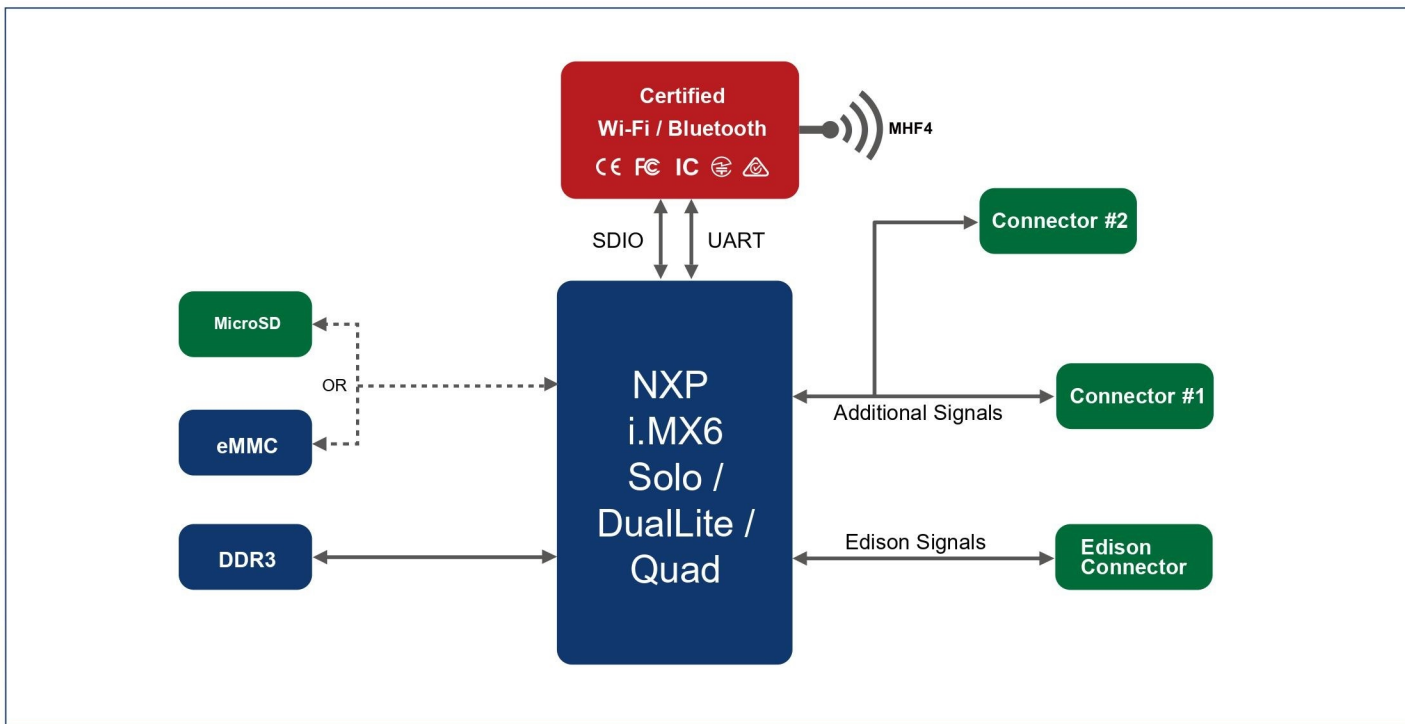

Environmental and Mechanical

Dimensions	37 x 40 mm / 1 5/8 x 1 5/8 inch
Form Factor	PICO Compute Module
Weight	8 grams
Temperature	Commercial: 0° to +60°C Extended: -20° to +70°C Industrial: -40° to +85°C
Relative Humidity	10 to 90 %
MTBF	>100 000 Hours
Shock	50G/25ms
Vibration	20G/0-600Hz

Power Specifications

Power Input	4.25-5.25 VDC
Power Consumption	Depending on Configuration

Dimensions
(units in mm)

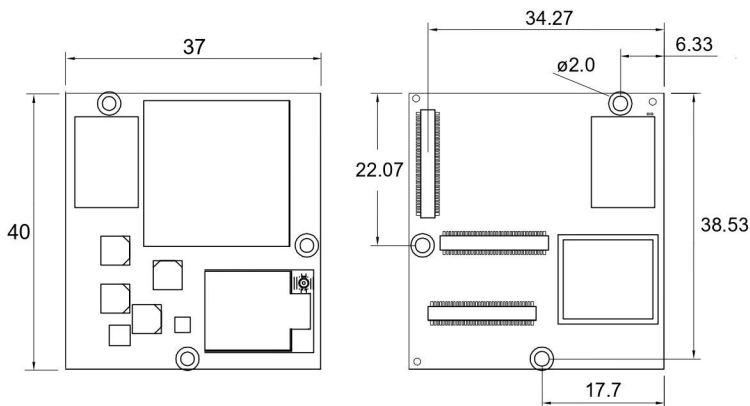

Order Information :

PICO-IMX6x-xx-Rxx-xxx-xxxx-xx-xxxx

	Code	Description
Processor	IMX6S	NXP i.M6Solo
	IMX6J	NXP i.MX6DualLite
	IMX6Q	NXP i.MX6Quad
Processor Speed	08	800MHz
	10	1GHz(Default)
Memory	R05	512 MB DDR3
	R10	1GB DDR3
	R20	2GB DDR3
Storage	MSD	MicroSD Cardslot
	E16	eMMC 16GB
	EXX	eMMC other capacity
Wi-Fi / Bluetooth	-	-
	9377	Qualcomm QCA9377 802.11a/b/g/n/ac (2.4 + 5GHz) + Bluetooth
Temperature Range	-	Commercial Temperature range (0° to +60°C)(Default)
	TE	Extended Temperature range (-20° to +70°C)
	TI	Industrial Temperature range (-40° to +85°C)
Custom ID	XXXX	Custom Part number ID for customized software loader and special component (BOM)